

KHP KHP3K系列板式液压球阀

1 型号说明

$\frac{KHB3K}{(1)} - \frac{10}{(2)} - \frac{L}{(3)} - \frac{1}{(4)} \frac{1}{(5)} \frac{1}{(6)} \frac{2}{(7)} - \frac{02}{(8)}$

(1)产品代号: KHP-板式二通

KHP3K-板式三通

(2)公称通径: 06、10、16...mm

(3)功能代号: L、T(二通阀无2)

(4)阀体、螺塞材料: 1—碳钢

(5)球体和控制芯轴材料: 1—合金钢

(6)球体密封碗材料: 1—POM

(7)其它密封本材料: 2—丁腈橡胶(NBR) 4—氟橡胶(FPM)

注): 材料1112为常规组合, 订货时可省略。



2 功能符号

注意: 该系列三通球阀只能从接口“1”进压力油阀的密封功能只能在以下两种情况有效:

1)关闭的油口压力为零;

2)关闭的油口压力小于两个通油口

L形 90°换向

T形 90°换向

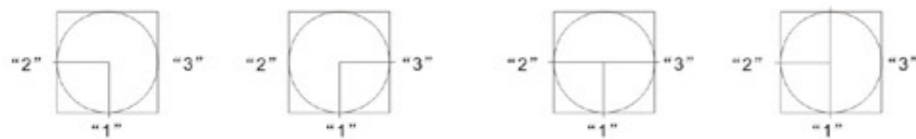

3 外形尺寸

1、KHP(PKH)

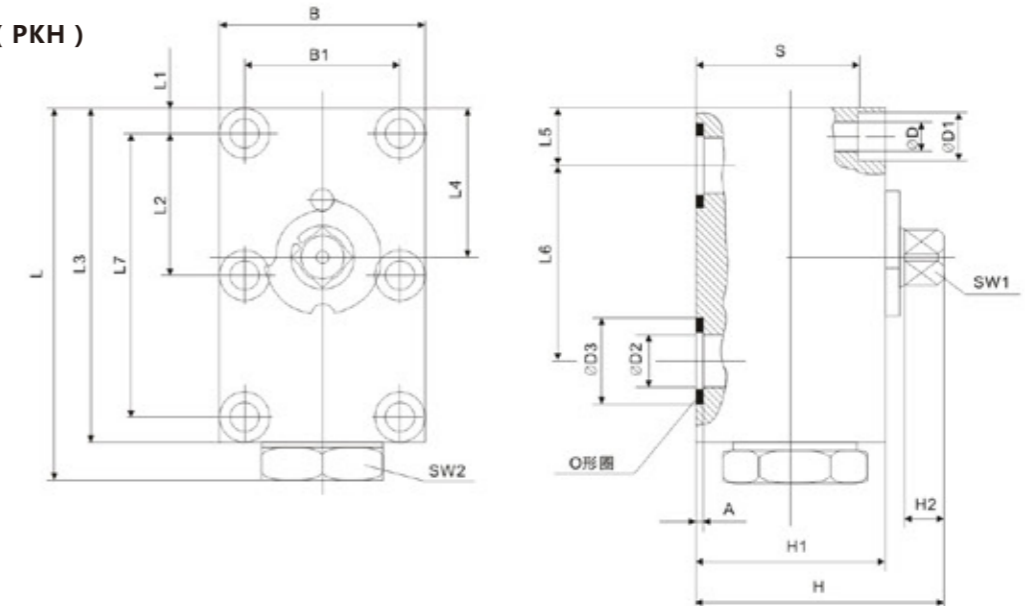

型号	DN	Lw	L	L1	L2	L3	L4	L5	L6	L7	B	B1
KHP(PKH)-06	6	6	64	8.5	17.5	59	25	8.5	35	35	40	27
KHP(PKH)-10	10	9.5	80	8	27.5	71	29.5	10	44	55	56	40
KHP(PKH)-16	16	16	110	8.5	41.5	100	43.5	17	58	83	60	45
KHP(PKH)-20	20	20	127	10	48.5	117	51	20	69	97	70	51
KHP(PKH)-25	25	25	145	10	57.5	135	62	24	81	115	80	60
KHP(PKH)-32	32	30	177	12	68	165	75	29	96	136	100	78
KHP(PKH)-40	40	38	192	28.5	56	180	85.5	28.5	112	112	130	95
KHP(PKH)-50	50	48	245	38	68	220	106	38	136	136	149	112

型号	SW1	SW2	H	H1	H2	D	D1	D2	D3	A	S	O-Ring/GB1235
KHP(PKH)-06	9	22	39	30	6	6.6	11	6	12	1.4	23	14x1.4
KHP(PKH)-10	9	30	54.5	42	8	9	13	9.5	16	1.8	33	16x2.4
KHP(PKH)-16	12	36	67.5	50	11	9	13	16	25	1.8	41	25x2.4
KHP(PKH)-20	14	41	80	55	12	10.5	16.5	20	30	2.4	51	30x3.1
KHP(PKH)-25	14	50	86	61	12	10.5	16.5	25	35	2.4	56	35x3.1
KHP(PKH)-32	17	65	110	76	14	13	19	32	40	2.4	77	40x3.1
KHP(PKH)-40	17	75	120	100	14	17.5	26	38	50	2.4	82	50x3.1
KHP(PKH)-50	17	75	130	110	14	22	33	48	56	2.7	88	56x3.5

型号	内六角螺栓DIN912(GB70-85)	扭矩MA(Nm)(摩擦系数为u0.14时的标准值)
KHP(PKH)-06	M6-10.9	13
KHP(PKH)-10	M8-10.9	30
KHP(PKH)-16	M8-12.9	35
KHP(PKH)-20	M10-12.9	60
KHP(PKH)-25	M10-12.9	60
KHP(PKH)-32	M12-12.9	110
KHP(PKH)-40	M16-12.9	300
KHP(PKH)-50	M20-12.9	600

KHP KHP3K系列板式液压球阀

(2)KHP3K

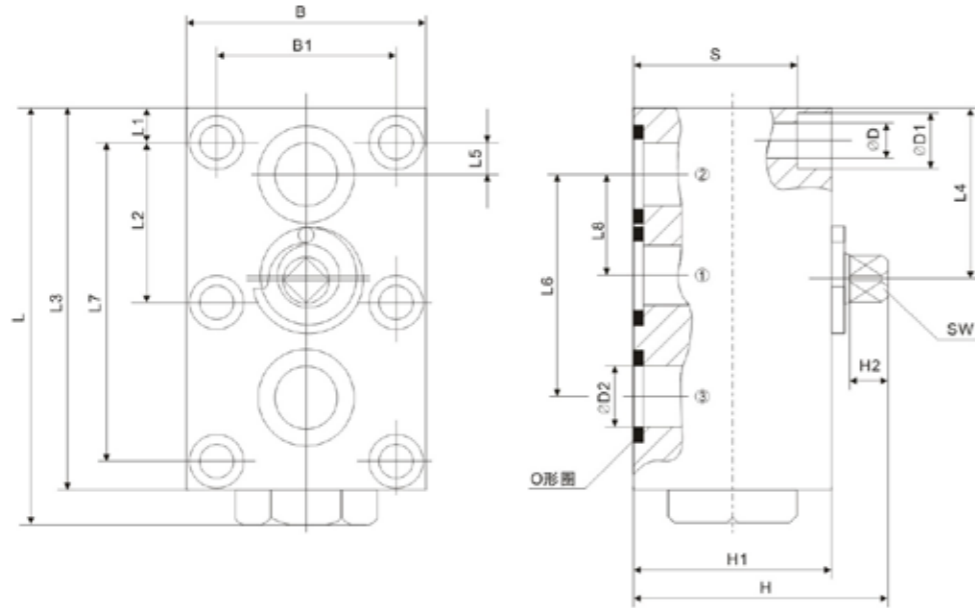

型号	L	L1	L2	L3	L4	L5	L6	L7	L8	B
KHP3K-06	64	8.5	17.5	59	25	0	35	35	17.5	40
KHP3K-10	80	8	27.5	71	29.5	2.5	44	55	19	56
KHP3K-16	110	8.5	41.5	100	43.5	8.5	58	83	26.5	60
KHP3K-20	127	10	48.5	117	51	10	69	97	32	70
KHP3K-25	145	10	57.5	135	62	14	81	115	38	80
KHP3K-32	177	12	68	165	75	17	96	136	46	100
KHP3K-40	192	28.5	56	180	85.5	0	112	112	56	130
KHP3K-50	245	38	68	220	106	0	136	136	68	149

型号	B1	H	H1	H2	D	D1	D2	S	SW	O形圈/GB1235
KHP3K-06	27	39	30	6	6.6	11	6	23	9	12x1.9
KHP3K-10	40	54.5	42	8	9	13.5	9.5	33	9	16x2.4
KHP3K-16	45	67.5	50	11	9	13.5	16	41	12	25x2.4
KHP3K-20	51	80	62	12	10.5	16.5	20	51	14	30x3.1
KHP3K-25	60	85	67	12	10.5	16.5	25	56	14	35x3.1
KHP3K-32	78	110	90	14	13	19	32	77	17	40x3.1
KHP3K-40	95	120	100	14	17.5	26	38	82	17	50x3.1
KHP3K-50	112	130	110	14	22	33	48	88	17	56x3.5

型号	KHP3K-06	KHP3K-10	KHP3K-16	KHP3K-20	KHP3K-25	KHP3K-32	KHP3K-40	KHP3K-50
安装螺钉/GB70-85	M6x30	M8x45	M8x50	M10x65	M10x70	M12x95	M16x110	M20x110
扭矩(Nm)	13	30	35	60	60	110	300	600

注: (1)螺钉强度10.9级, 表中长度为参考值。可根据S尺寸配备螺钉, 螺纹旋入长度为螺纹外径的1.25~1.5倍。
(2)扭矩为当摩擦系数u0.14时的标准值。

KHB-AS KHM-AS系列球阀(带焊接管)

1 产品简介

公称压力:PN160bar
公称口径:DN10—50/65
工作温度:-20°C—100°C

2 型号说明

KHB-AS - $\frac{160}{(1)}$ - $\frac{20}{(2)}$ - $\frac{1}{(3)}$ $\frac{1}{(4)}$ $\frac{1}{(5)}$ $\frac{2}{(6)}$ - $\frac{02}{(7)}$

- (1)产品代号: KHB--AS
KHM--AS
(2)压力范围: 160bar(3)公称口径:06~65mm
(4)阀体材料: 1-碳钢; 2-不锈钢
(5)球体材料: 1-合金钢; 3-不锈钢
(6)球体密封碗材料: 1——POM; 4——聚四氟乙烯(PTFE)
(7)阀体和接头处密封: 2——丁腈橡胶(NBR); 4—氟橡胶(FPM)
注): 材料1112为常规材料, 订货时可省略。



3 外形尺寸

KHB—AS

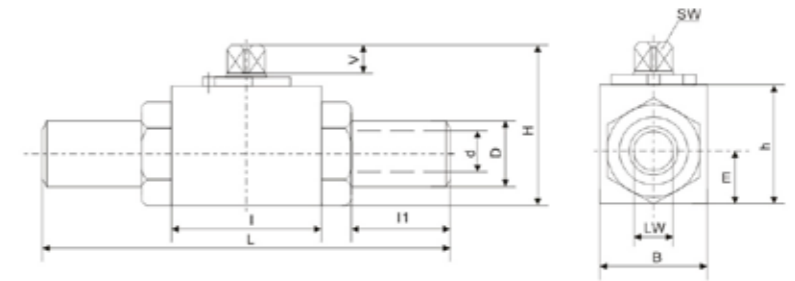

KHM—AS

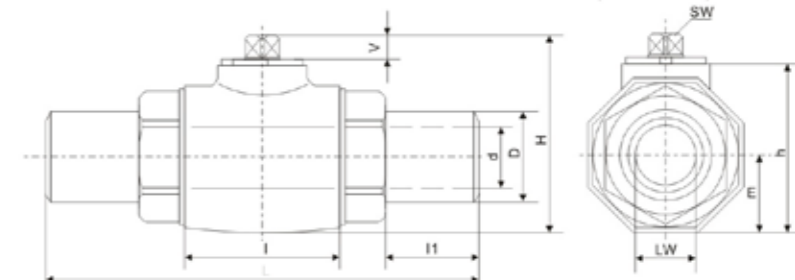

型号	DN	PN	LW	L	I	H	B	h	m	v	I1	d	D	SW
KHB-AS160-10	10	160	10	150	42	52.5	32	40	17	8	42	10	17.2	9
KHB-AS160-13	13	160	13	180	48	52.5	35	40	17	8	51	13	21.3	9
KHB-AS160-16	16	160	15	180	47	63.5	38	46	19	11	55	15	21.3	12
KHB-AS160-20	20	160	20	200	60	75	48	57	24	12	50	20	26.9	14
KHB-AS160-20/25	20/25	160	20	200	60	75	48	57	24	12	50	25	33.7	14
KHB-AS160-25	25	160	25	210	65	82	57	64	28.5	12	51	25	33.7	14
KHB-AS160-25/32	25/32	160	25	210	65	82	57	64	28.5	12	51	30	42.2	14
KHM-AS160-32	32	160	30	260	84	104.5	75	84	37.5	14	70	30	42.2	17
KHM-AS160-32/40	32/40	160	30	260	84	104.5	75	84	37.5	14	70	38	48.3	17
KHM-AS160-40	40	160	38	270	91	115.5	85	95	42.5	14	72	38	48.3	17
KHM-AS160-40/50	40/50	160	38	270	91	115.5	85	95	42.5	14	72	48	60.3	17
KHM-AS160-50	50	160	48	300	100	133	105	112.5	52.5	14	72	48	60.3	17
KHM-AS160-50/65	50/65	160	48	300	100	133	105	112.5	52.5	14	72	63	76.1	17